

The SCL Series combines maintenance innovations with performance and dependability in a compact, specification grade, steel enclosure.

Model: \_\_\_\_\_ Date: \_\_\_\_\_  
Accessories: \_\_\_\_\_  
Job Name: \_\_\_\_\_ Type: \_\_\_\_\_

### FEATURES AND BENEFITS

- Tool-less front battery accessibility for ease of maintenance
  - Isolated battery compartment for safe installation and maintenance
  - Hinged door helps prevent loss or misplacement during installation and maintenance
- Patent pending Numeric Indicator option for error-proof visual display of fault detection/status (G2-NI)
- Assembled in the USA with global components



### SPECIFICATIONS

- Illumination:** Fully adjustable PAR16 style (REN3M) 3.6W or (REN3) 2.9W LED lamps deliver industry-leading spacing up to 60'
- Housing:** Compact enclosure constructed of rugged 20 gauge steel
- Input:** 120/277VAC Dual primary, 50/60Hz input
- Battery:** Maintenance-free 6V NiMH battery
- Operating Temp:** 20°C to 30°C (68°F to 86°F)
- Run Time:** 90 minute emergency run time, 24 hour recharge time
- Mounting:** Wall or pendant (with available accessory)
- Finishes:** White
- Certifications:** UL Listed
- Warranty:** Any component that fails due to a manufacturing defect is guaranteed for five years with a separate five year prorated warranty on the battery. The warranty does not cover physical damage, abuse or instances of uncontrollable natural forces. See the full Exitronix warranty documentation for more detailed information. (Terms and Conditions apply)

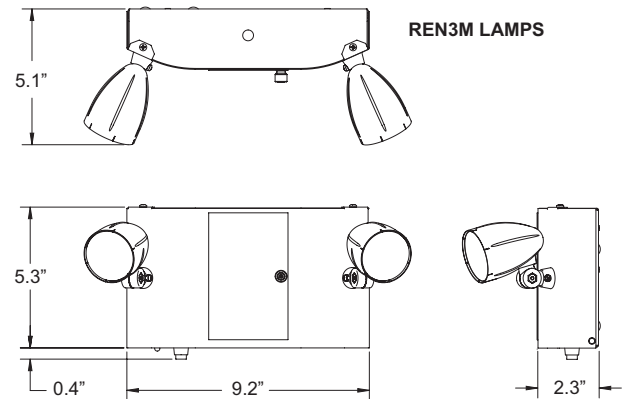

### ORDERING INFORMATION

Model	Description	Accessories <sup>1</sup> (Field Installed)
SCL-8-REN3-2-W-G2	8W, 2 Renegade 2.9W LED Lamps, Self-Test/Self-Diagnostics, White	ER1-KIT-WH = 1' Pendant Kit, White
SCL-8-REN3M-2-W-G2-NI	8W, 2 Renegade Max 3.6W LED Lamps, Self-test/Self-diagnostics with Numeric Indicator, White	ER2-KIT-WH = 2' Pendant Kit, White
		WG-S = Wire Guard (Back Mount)

#### Notes

<sup>1</sup> Order as separate line item

## CONSTRUCTION

The SCL Series features a two-piece die-formed 20 gauge steel enclosure with epoxy powder coat in a standard white finish. Universal J-box mounting pattern and keyhole slots provided for simple installation. Hinged battery access door with captive thumb screw provides tool-less battery access. Low voltage battery compartment isolated from line voltage for safe battery access. A velcro battery strap is included as an additional safety feature.

## ILLUMINATION

Two fully adjustable (REN3M) 3.6W or (REN3) 2.9W LED thermoplastic lamp heads with a 12° narrow beam standard optic maximize light delivered to the path of egress.

## ELECTRICAL

### Input

Dual-voltage input 120 or 277VAC @ 50/60Hz

### Nickel Metal Hydride Battery – NiMH

Extronix 6V nickel metal hydride batteries are maintenance-free.

### Emergency

The SCL Series will operate for a minimum of 90 minutes during a loss of power with a 24 hour maximum recharge time for the battery.

### Brownout Circuit

The brownout circuit monitors the line voltage. As the line voltage sags and can no longer provide adequate voltage, the emergency lighting circuit will turn on to supply power to the emergency lamps for 90 minutes until the line voltage is restored.

### Low Voltage Disconnect

Low voltage disconnect (LVD) measures the battery terminal voltage and if it should fall below a preset voltage threshold, the LVD will disconnect the load. When the battery is recharging and voltage is raised above another preset threshold, the load is automatically reconnected.

### Overload and Short Circuit Protection

The Overload monitoring system in the DC circuit disconnects the lamp load from the battery should excessive wattage demands be made.

### Test Button

The test button is easy to locate and provides manual verification of the transfer circuit and emergency lamps.

## INSTALLATION

A universal mounting pattern and rear keyhole slots are provided for wall mounting.

## OPTIONS

### Guardian Self-Test/Self-Diagnostics with Numeric Indicator (Option: G2-NI, Included Standard)

The Guardian circuit continuously monitors the operating condition of the AC power, battery supply voltage, emergency lamp continuity and charging circuit.

The purpose of this option is to provide visual signaling in response to a fault with a lamp, battery and/or battery charger. If a failure is detected, visual status will occur immediately via the Numeric Indicator. The code will display until the fault is corrected.

The Guardian circuit also monitors the transfer circuit as well as performing automatic code compliant testing. The Guardian circuit will automatically test the unit in accordance to NFPA 101 specification. A one minute manual test can be initiated by the user.

Code	Description
0	Float Charge
1	High Rate Charge
2	Discharging
3	Charger Failure
4	Battery Disconnected

Code	Description
5	Lamp Failure
6	Low Battery Voltage
7	Manual Testing
8	Self Testing

## CONFORMANCE TO CODES & STANDARDS

The SCL Series is UL Listed and meets or exceeds NEC requirements and NFPA 101.

## SAMPLE PHOTOMETRICS

Using multiple units mounted at a typical 7.5' height delivers 60' center-to-center spacing on a 6' wide egress path.

